



CH-1602TXR & CH-1602RXR

HDMI over HDBaseT Transmitter and Receiver
with Optical Audio Return (OAR)



Operation Manual



HDMI[®]
HIGH-DEFINITION MULTIMEDIA INTERFACE

The terms HDMI, HDMI High-Definition Multimedia Interface, and the HDMI Logo are trademarks or registered trademarks of HDMI Licensing Administrator, Inc.

DISCLAIMERS

The information in this manual has been carefully checked and is believed to be accurate. Cypress Technology assumes no responsibility for any infringements of patents or other rights of third parties which may result from its use.

Cypress Technology assumes no responsibility for any inaccuracies that may be contained in this document. Cypress also makes no commitment to update or to keep current the information contained in this document.

Cypress Technology reserves the right to make improvements to this document and/or product at any time and without notice.

COPYRIGHT NOTICE

No part of this document may be reproduced, transmitted, transcribed, stored in a retrieval system, or any of its part translated into any language or computer file, in any form or by any means—electronic, mechanical, magnetic, optical, chemical, manual, or otherwise—without express written permission and consent from Cypress Technology.

© Copyright 2018 by Cypress Technology.

All Rights Reserved.

TRADEMARK ACKNOWLEDGMENTS

All products or service names mentioned in this document are trademarks of the companies with which they are associated.



SAFETY PRECAUTIONS

Please read all instructions before attempting to unpack, install or operate this equipment and before connecting the power supply. Please keep the following in mind as you unpack and install this equipment:

- Always follow basic safety precautions to reduce the risk of fire, electrical shock and injury to persons.
- To prevent fire or shock hazard, do not expose the unit to rain, moisture or install this product near water.
- Never spill liquid of any kind on or into this product.
- Never push an object of any kind into this product through any openings or empty slots in the unit, as you may damage parts inside the unit.
- Do not attach the power supply cabling to building surfaces.
- Use only the supplied power supply unit (PSU). Do not use the PSU if it is damaged.
- Do not allow anything to rest on the power cabling or allow any weight to be placed upon it or any person walk on it.
- To protect the unit from overheating, do not block any vents or openings in the unit housing that provide ventilation and allow for sufficient space for air to circulate around the unit.
- Please completely disconnect the power when the unit is not in use to avoid wasting electricity.

VERSION HISTORY

REV.	DATE	SUMMARY OF CHANGE
VR0	2015/08/21	Preliminary release
VS1	2017/03/22	Updated text/diagrams



CONTENTS

1. Introduction	1
2. Applications	1
3. Package Contents	1
4. System Requirements	2
5. Features	2
6. Operation Controls and Functions	3
6.1 Transmitter's Front Panel	3
6.2 Transmitter's Side Panels.....	4
6.3 Receiver's Front Panel	5
6.4 Receiver's Side Panels.....	6
6.5 IR Cable Pin Assignment.....	7
7. Connection Diagram	8
8. Specifications	9
9. Acronyms	10





1. INTRODUCTION

This HDBaseT 2.0 Transmitter and Receiver set can send uncompressed UHD video and audio over a single Cat.5e/6/7 cable up to 100m. It has the added benefit of extending control and communication signals through the built-in Ethernet, RS-232 and IR ports. Independent external digital and analog audio transmission capability gives users the extra convenience of additional audio connections.

The integrated 48V PoH (Power over HDBaseT) support provides power to the Receiver (PD) from the Transmitter (PSE), eliminating the need for a separate power supply for the Receiver. The ultra-thin mechanical design allows for flexibility in mounting locations, saving space and making your presentation space orderly and tidy.

2. APPLICATIONS

- Home theater extension and control
- Lecture hall display and control
- Showroom display and control
- Meeting room presentation and control
- Classroom display and control

3. PACKAGE CONTENTS

- 1×HDMI over HDBaseT Transmitter
- 1×HDMI over HDBaseT Receiver
- 1×IR Extender Cable
- 1×IR Blaster Cable
- 4×Terminal Blocks (3-pin)
- 1×48V/0.83A Power Adaptor
- 1×Power Cord
- 2×Rack Mount Ears (Set of 2)
- 1×Operation Manual

4. SYSTEM REQUIREMENTS

- HDMI input source equipment such as media players, video game consoles, PCs or set-top boxes.
- HDMI receiving equipment such as HDTVs, monitors or audio amplifiers.
- The use of “Premium High Speed HDMI” cables is highly recommended.
- High quality Cat.5e/6/7 cables (Cat.6 or better is recommended).

5. FEATURES

- Supports the HDBaseT 2.0 specification over a single Cat.6/7 cable up to 100m/328ft and Cat.5e cable up to 90m/295ft
- HDBaseT 5Play™ convergence: High-Definition (HD) Video and Audio, 100BaseT Ethernet, 48V PoH, and Control (Bi-directional IR/RS-232 pass-through)
- Receiver (PD) is powered by 48V PoH from the transmitter (PSE)
- HDMI with 3D & 4K@60Hz (YUV 4:2:0) support, DVI 1.0 compatible
- HDCP 2.2 compliant
- Supports pass-through of HD audio formats: LPCM 2.0/5.1/7.1, Bitstream, and HD Bitstream
- Supports optical audio sampling rates up to 48kHz
- Supports external analog and digital audio extension including support for ARC (Audio Return Channel)
- Supports RS-232 baud rates from 110~115200bps
- Ultra-thin mechanical design

6. OPERATION CONTROLS AND FUNCTIONS

6.1 Transmitter's Front Panel

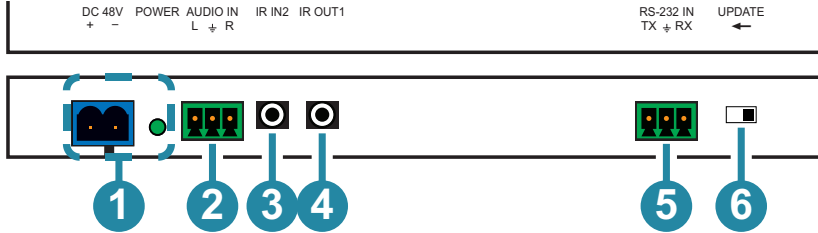

- 1 DC 48V & POWER LED:** Plug the 48V DC power adapter into this port and connect it to an AC wall outlet for power. The LED will illuminate to indicate the unit is on and receiving power.
- 2 AUDIO IN:** Connect to the stereo analog output of a device such as a CD player or PC to extend it to the Receiver's AUDIO OUT L/R port.
- 3 IR IN 2:** Connect to the provided IR Extender to extend the IR control range of remotely located devices. Ensure that the remote being used is within direct line-of-sight of the IR Extender.
- 4 IR OUT 1:** Connect to the provided IR Blaster to transmit IR signals to devices within direct line-of-sight of the IR Blaster.
- 5 RS-232 IN:** Connect to a PC, laptop or other serial control device with a 3-pin adapter cable for the extension of RS-232 signals to the Receiver. When receiving commands from the Receiver side, depending on your equipment's pinout, the Tx and Rx pins might need to be reversed.
- 6 UPDATE:** This is reserved for firmware update use only. During normal operation the dipswitch should be set to the right.

6.2 Transmitter's Side Panels

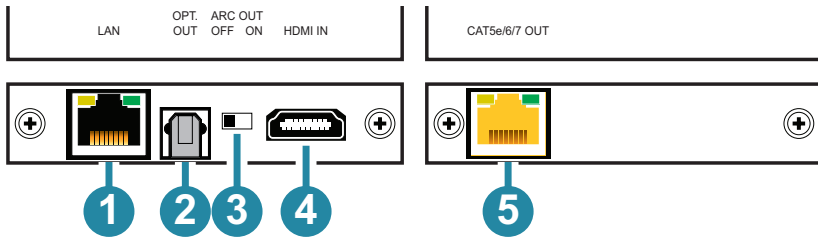

- 1 **LAN:** Connect to an Ethernet supporting device or to your local network as appropriate. The yellow LED will illuminate to indicate a successful LAN connection between the Transmitter and Receiver and will blink to indicate a data transmission. The green LED will illuminate when the connected Ethernet speed is 100Mbit/s.
- 2 **OPT. OUT:** Connect to an audio receiver or powered speaker set to reproduce the audio signal from the Receiver's OPT. IN port.
- 3 **ARC OUT ON/OFF:** Enables or disables support for ARC (Audio Return Channel) signals from the HDMI device connected to the Receiver. When switched to ON the ARC audio will be routed to both the HDMI input as well as the OPT. OUT port. When switched OFF no ARC audio will be passed.

Note: When ARC is enabled the maximum supported HDMI cable length may vary. It is suggested to use cables under 2 meters long to ensure the best audio quality.

- 4 **HDMI IN:** Connect to HDMI source equipment such as a media player, game console or set-top box.
- 5 **CAT5e/6/7 OUT:** Connect to the Receiver unit with a single Cat.5e/6/7 cable for transmission of all data signals. The yellow LED will illuminate to indicate a successful data connection between the Transmitter and Receiver. If the yellow LED blinks irregularly it indicates a data link error. The green LED will illuminate to indicate when PoH is active.

6.3 Receiver's Front Panel

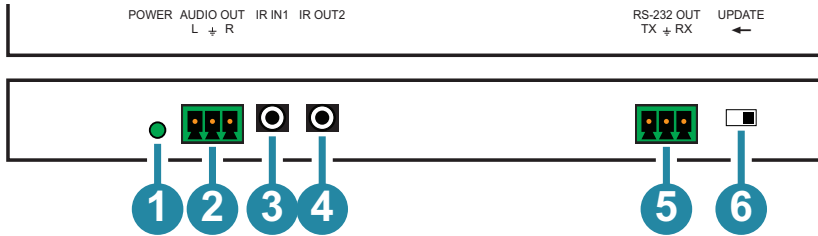

- 1 POWER LED:** This LED will illuminate when the device is receiving power.
- 2 AUDIO OUT:** Connect to powered speakers or an amplifier for stereo analog audio output.
- 3 IR IN 1:** Connect to the provided IR Extender to extend the IR control range of remotely located devices. Ensure that the remote being used is within direct line-of-sight of the IR Extender.
- 4 IR OUT 2:** Connect to the provided IR Blaster to transmit IR signals to devices within direct line-of-sight of the IR Blaster.
- 5 RS-232 OUT:** Connect to the device you wish to control via a 3-pin adapter cable to receive RS-232 commands from the Transmitter. When sending commands to the Transmitter side, depending on your equipment's pinout, the Tx and Rx pins might need to be reversed.
- 6 UPDATE:** This is reserved for firmware update use only. During normal operation the dipswitch should be set to the right.

6.4 Receiver's Side Panels

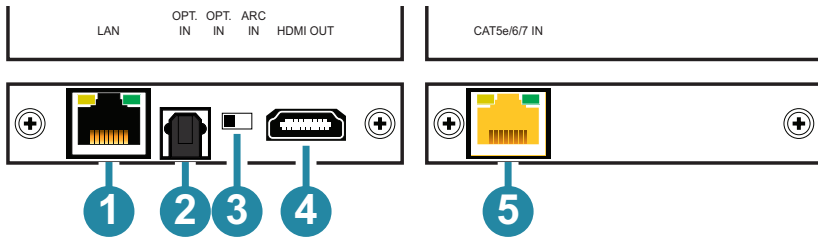

- 1 **LAN:** Connect to an Ethernet supporting device or to your local network as appropriate. The yellow LED will illuminate to indicate a successful LAN connection between the Transmitter and Receiver and will blink to indicate a data transmission. The green LED will illuminate when the connected Ethernet speed is 100Mbit/s.
- 2 **OPT. IN:** Connect to audio source equipment such as a media player or PC to transmit the audio signal to the Transmitter's OPT. OUT port.
- 3 **ARC IN/OPT. IN:** Allows you to switch between sending audio to the Transmitter from the HDMI output's ARC channel or from the Receiver's OPT. IN port.

Note: When ARC is enabled the maximum supported HDMI cable length may vary. It is suggested to use cables under 2 meters long to ensure the best audio quality.

- 4 **HDMI OUT:** Connect to HDMI TVs, monitors or amplifiers for digital video and audio output.
- 5 **CAT5e/6/7 IN:** Connect to the Transmitter unit with a single Cat.5e/6/7 cable for transmission of all data signals. The yellow LED will illuminate to indicate a successful data connection between the Transmitter and Receiver. If the yellow LED blinks irregularly it indicates a data link error. The green LED will illuminate to indicate when PoH is active.

6.5 IR Cable Pin Assignment

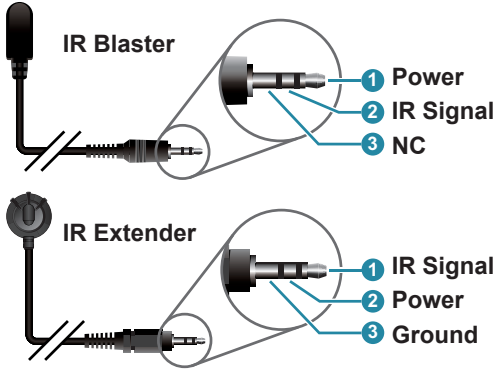

7. CONNECTION DIAGRAM

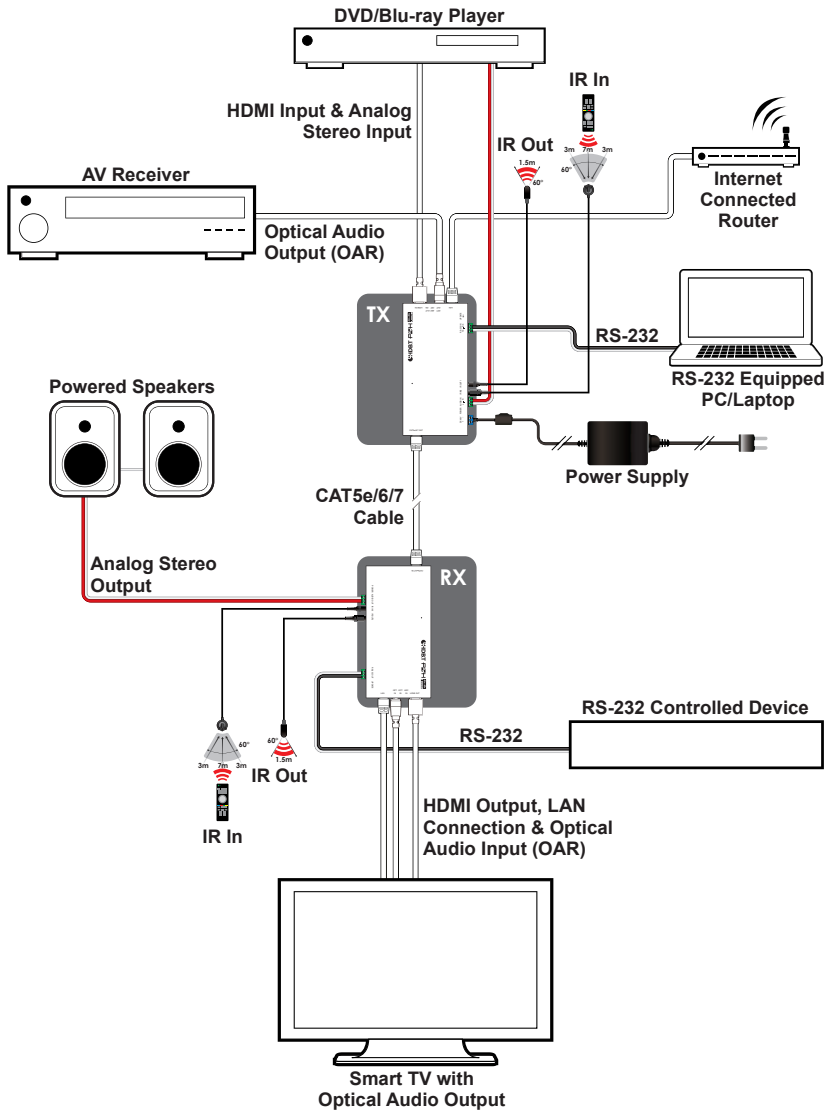

8. SPECIFICATIONS

Video Bandwidth	340MHz/10.2Gbps
<i>Transmitter</i>	
Input Ports	1×HDMI, 1×Stereo Audio (Terminal Block), 1×LAN (RJ45), 1×IR Extender (3.5mm), 1×RS-232 (Terminal Block)
Output Ports	1×Cat.5e/6/7, 1×Optical Audio (TOSLINK), 1×IR Blaster (3.5mm)
<i>Receiver</i>	
Input Ports	1×Cat.5e/6/7, 1×Optical Audio (TOSLINK), 1×IR Extender (3.5mm)
Output Ports	1×HDMI, 1×Stereo Audio (Terminal Block), 1×LAN (RJ45), 1×IR Blaster (3.5mm), 1×RS-232 (Terminal Block)
Supported Resolutions	480i@60Hz - 4K@60Hz (4:2:0, 8-bit) VGA@60Hz - WUXGA@60Hz (RB)
HDMI Cable Length	10m (1080p@60Hz, 12-bit) 5m (4K@60Hz, 4:2:0, 8-bit)
Cat.5e Cable Length	100m (1080p@60Hz, 12-bit) 90m (4K@60Hz, 4:2:0, 8-bit)
Cat.6/7 Cable Length	100m (1080p@60Hz, 12-bit) 100m (4K@60Hz, 4:2:0, 8-bit)
IR Frequency	30 - 50kHz (30 - 60kHz under ideal conditions)
Baud Rate	Up to 115200bps
Power Supply	48V/0.83A DC (US/EU standards, CE/FCC/UL certified)
ESD Protection	Human Body Model: ±12kV (Air Discharge) ±8kV (Contact Discharge)

Dimensions	180mm×16mm×80mm (W×H×D) [Case Only] (Both) 180mm×16mm×80mm (W×H×D) [All Inclusive] (Both)
Weight	354g (TX), 356g (RX)
Chassis Material	Aluminum
Silkscreen Color	Black
Operating Temperature	0°C - 40°C/32°F - 104°F
Storage Temperature	-20°C - 60°C/-4°F - 140°F
Relative Humidity	20 - 90% RH (Non-condensing)
Power Consumption	15.5W

9. ACRONYMS

ACRONYM	COMPLETE TERM
ARC	Audio Return Channel
DVI	Digital Visual Interface
HDCP	High-bandwidth Digital Content Protection
HDMI	High-Definition Multimedia Interface
IR	Infrared
LAN	Local Area Network
LPCM	Linear Pulse-Code Modulation
PC	Personal Computer
PD	Powered Device
PoH	Power over HDBaseT
PSE	Power Source Equipment
UHD	Ultra-High-Definition
VGA	Video Graphics Array (640×480@60Hz)
WUXGA	Wide Ultra Extended Graphics Array (1920×1200@60Hz)



CYPRESS TECHNOLOGY CO., LTD.
www.cypress.com.tw
